

X3

Automatic Screen and Stencil Printer



Description

Screen printing machine X3 for printing PCBs and flat assemblies with solder paste, glue or arbitrary functional layers. Stencil frames from 350 x 350 mm to 736 x 736 mm can be used directly, without adapters and are clamped using pneumatics to the upper assembly. A combination of a squeegee and a flood bar or of 2 squeegees, can be built into the very accurate, double squeegee-head. This ensures a constant squeegee pressure over the entire print path. Different print variations can be pre-selected on the machine PC and can be saved along with the print parameters. The PCB or the current printing matter can be fixed in the print position with hold-down rails, side clamps or a vacuum.

Special Features

- _ Automatic inline system
- _ Optical positioning system
- _ PC controlled unit
- _ User friendly software
- _ Repeat accuracy +/- 25 µm @ 3 Sigma
- _ Stencil cleaning

X3 Automatic Screen and Stencil Printer

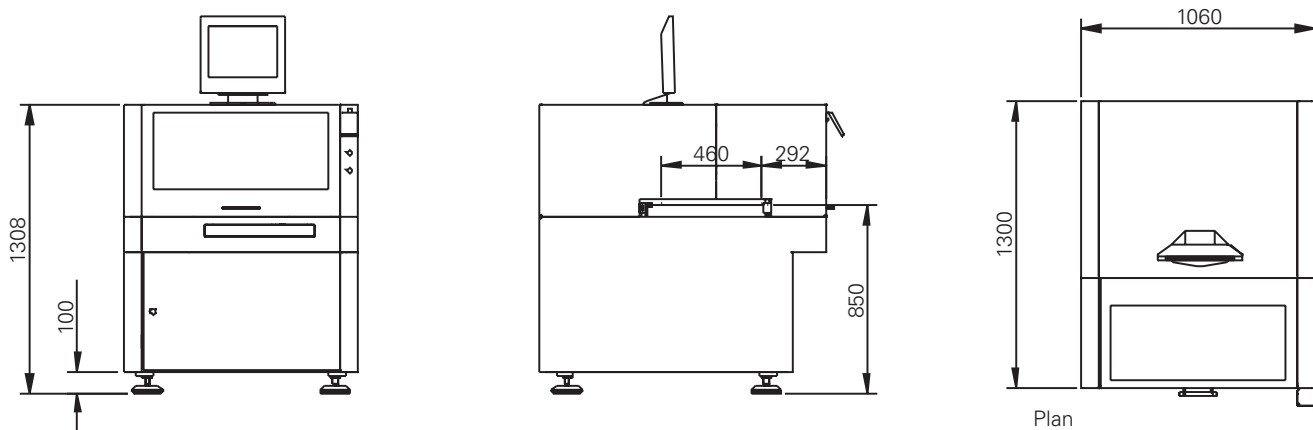

Machine dimensions

Length x width x height *	1060 x 1300 x 1308 mm
Weight	ca. 650 kg
Floor load	351 kg / m ²
Colour	RAL 9003

Installation requirements

Power supply	230 V, 208V; 50 / 60 Hz, 1+N+PE
Power consumption	1,2 kW
Fuse protection	16 A
Operating voltage	24 V
Air supply	5 - 6 bar
Air consumption	10 -15 l / min

Print Parameters

Print speed	5 - 200 mm/s
Print pressure	50 - 260 N
Print mode	Print - Print Print - Flood Flood - Print Alternating print

Material to be printed

Frame size min.	300 x 300 mm
Frame size max.	736 x 736 mm
Print format min.	50 x 80 mm
Print format max.	460 x 460 mm
Print material thickness	0,5 - 6 mm
Positioning	Optical fiducial recognition

Machine Capability

Alignment accuracy	+/- 25 µm @ 3 Sigma
Cycle time	13 s plus Print time

* other dimensions on request

Options

Squeegee head self-calibration device
Automatic paste dispenser
Air conditioning

Specifications are subject to change without prior notice. Please check with your local sales contact for the latest.