

## Benchtop High Resolution, High Speed Automated Optical Inspection System

# BF-Sirius

### High Resolution Optical System

With a superior resolution of 18 $\mu$ m and a scanning line color CCD camera, the BF-Sirius provide accurate and stable inspection results. Solder fillets on components as small as the high density mounted 0201 (0603) chip, as well as IC's with 0.4mm pitch lead are easily inspected and analyzed.

### High Throughput

BF-Sirius has Saki's original alternate scanning system that captures several lighting images in one scanning. Newly developed color capturing system enable to make scanning speed twice faster than previous model. BF-Sirius takes only 10 seconds to capture L-size board [460mm  $\times$  500mm]. Overall tact time including inspection also become shortened dramatically.

### New Interface

Renewed user interface makes it easier to set up inspection data by using pre-installed Saki standard library. And optional new function KPK, that finds out the difference between surface of the board and the surface of component automatically, simplifies to detect missing component. This realizes time reduction for inspection data making at launching production.

### Advantage of Line Scan Visual Inspection

Extra components on the board can be detected only by setting up one inspection window on the whole board. It is realized by the advantage of line scan method.

### Coaxial Overhead Light

Soldering condition is inspected by illuminant irradiation of coaxial overhead lighting. Inspection is not affected by shadowing by neighboring tall components, therefore same library is available at any location on the board.

### Flexibility

BF-Sirius has 40mm clearance at the top side of the board and 60mm at the bottom side. It enables most of the PCBs with tall components. In addition, BF-Sirius can be used in any stage of the PCB production process from post-print, post-mounter, and post-flow / re-flow, or manual mounting.

### Traceability

Optional function of BF-Sirius can read all types of Barcode and 2D code on the board. Inspection output is reported with code number. It enables easy SPC data handling and log data management on manufacturing lines.



**Dimensions**

■ **Front View**

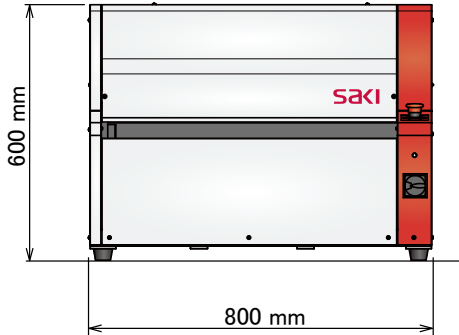

■ **Side View**

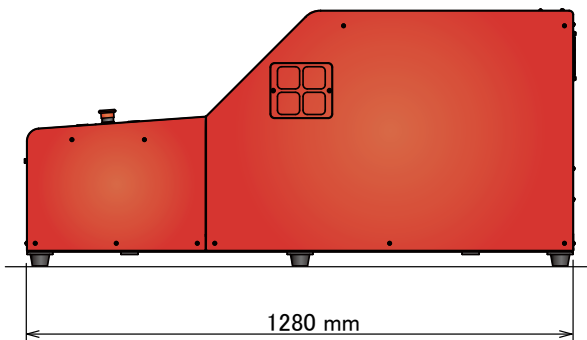

**System Specifications**

Model	BF-Sirius
Resolution	18µm
Board Size	50×50 - 460×500mm, 2×2 - 18×20in.
Board Thickness	0.6 - 2.5mm, 24 - 100mils
Board Warp	+/-2mm, 79mils
PCB Clearance	Top: 40mm, 1.57in. Bottom: 60mm, 2.36in.
Rotated Component Support	Available for 0 - 359°rotation (unit of 1°)
Inspection Categories	Presence/Absence, Misalignment, Tombstone, Reverse, Polarity, Bridge, Foreign material, Absence of solder, Insufficient solder, Lifted lead, Lifted Chip, and Fillet defect. Each defect name can be changed freely by system function.
Tact Time*1 *2 (460×500mm)	Approx. 18sec.
Image Scanning Time*1 (460×500mm)	Approx. 10sec.
Camera (Image Processing)	Line color CCD camera
Lighting	LED lighting system
Operating System	Windows XP English Version
Optional System	BF-Editor / BF-RP1 / BF-View
Optional	2D Barcode Recognition, Journal Printer, OK/NG Signal Out

\*1 If PCB size is smaller than 460x500mm, Image scanning time will be shorter than this values.  
 \*2 Including Image Scanning Time.

**System Requirements**

Electric Power Requirement	Single Phase ~100 - 120V / 200 - 240V +/-10%, 50/60Hz
Power Consumption	700VA
Air Requirement	Not needed
Usage Environment	15°C(59F) - 30°C(86F) / 15 - 80%RH (Non-condensing)
Dimensions W x D x H (Main body)	800 × 1280 × 600mm, 31.50 × 50.39 × 23.62in.
Weight (Excluding Monitor and PC)	Approx. 175 kg, 386lbs

**saki Saki Corporation**

URL:<http://www.sakicorp.com> E-mail:[sakicorp@sakicorp.com](mailto:sakicorp@sakicorp.com)

**Headquarters**

Ogawa Building, 4-14-7, Nakanobu, Shinagawa-ku, Tokyo, Japan, 142-0053  
 TEL: +81-3-5788-6280 FAX: +81-3-5788-6295

**Saki (Shanghai) CO., LTD**

Room 809, Kerry Everbright City, No. 218 West Tian Mu Road, Zhabei District, Shanghai 200070, P.R.C.  
 TEL: +86-21-6282-2266 FAX: +86-21-5230-5002

**Saki America, Inc.**

2378C Walsh Ave Santa Clara, CA 95051, USA  
 TEL: +1-408-567-0300 FAX: +1-408-727-7810

**Global Network**

**Germany office (Munich)**

TEL: +49-89-309-04-69-0  
 FAX: +49-89-309-04-69-99

**Asia Pacific office (Singapore)**

TEL: +65-6496-7711  
 FAX: +65-6496-7722

**China office (Shenzhen)**

TEL: +86-755-2583-8315  
 FAX: +86-755-2583-8317

**Taiwan office (Taipei)**

TEL: +886-3-312-6868  
 FAX: +886-3-312-6767

**Korea office (Seoul)**

TEL: +82-31-222-6144  
 FAX: +82-31-222-6744

**Thailand office (Bangkok)**

TEL: +66-2958-8380  
 FAX: +66-2958-8232

**Mexico office (Guadalajara)**

TEL: +52-1333-440-7032